



Item # \_\_\_\_\_

Project \_\_\_\_\_

Date \_\_\_\_\_



## Models CS-LL/CW-1 Shuttle & Warmer

### Standard Features CS-LL:

- 1.5 gallon (5.7L) stainless steel Shuttle
- Radiant heat, air insulated to protect coffee from direct contact with heat
- Easy grip handle
- Easy-to-clean round features

### Standard Features CW-1:

- Warmer for 1.5 gallon (5.7L) Shuttle
- Easy-to-clean round features



**GRINDMASTER™**  
CORPORATION



# Models CS-LL/CW-1

## Shuttle & Warmer

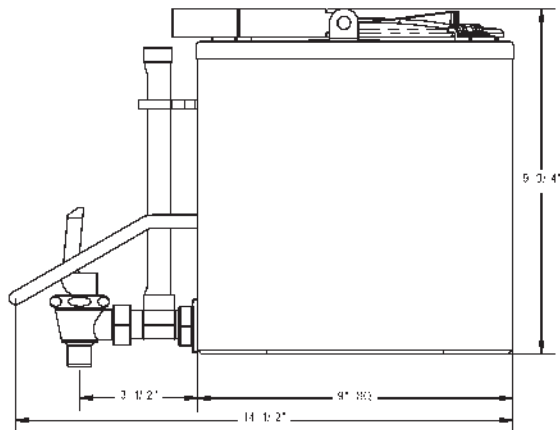

**Model CS-LL**

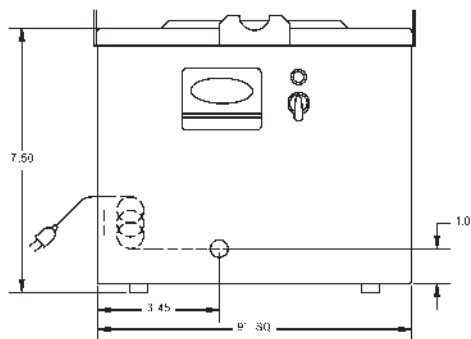

**Model CW-1**

Model	CS-LL	CW-1
<b>Voltage</b>	N/A	120V
<b>Kw</b>	N/A	0.1Kw
<b>Amps</b>	N/A	1 Amp
<b>Capacity</b>	1.5 gal (5.7L)	N/A
<b>Dimensions (H x W x D)</b>	9-3/4" x 9" x 14-1/2" (25 cm x 23 cm x 37 cm)	7-1/2" x 9" x 9" (19 cm x 23 cm x 23 cm)
<b>Ship Dimensions</b>	12-1/2" x 10-1/2" x 16-1/4" (32 cm x 27 cm x 41 cm)	12-1/2" x 10-1/2" x 16-1/4" (32 cm x 27 cm x 41 cm)
<b>Ship Weight</b>	11 lbs (5 kg)	6 lbs (2.7 kg)
<b>Listings</b>	NSF, CE	UL, CSA

Specifications are subject to improvement or change without notice.



**GRINDMASTER™**  
CORPORATION



Grindmaster® Coffee Grinders and Brewers • Espresso® Espresso Machines • Crathco® Hot Beverage Dispensers  
Crathco® Cold and Frozen Beverage Dispensers • American Metal Ware® Coffee and Tea Systems

Tel (502) 425-4776 • Fax (502) 425-4664 • 1-800-695-4500

P.O. Box 35020 • Louisville, KY 40232 • USA

www.grindmaster.com • email: info@grindmaster.com